



PROBE DIGITIZING MANUAL

Table of Contents

Section 1: INSTALLATION

Probe Interface	2
Computer Interface (RS-232-C)	5
Power Supply for the PC Computer	5
Static Electricity	6
Environmental Contaminants	5
Disk Handling Precautions	6
Software Installation	5

Section 2: START UP

Main Menu	7
Exiting the Software	7
Data Entry	8
Setting the Z Axis	8

Section 3: DIGITIZING

Digitize From Beginning	9
XY Pattern (2D Path)	9
XZ, YZ Pattern	13
Resume Digitizing 3D Program	19
Digitize Options	19

Section 4: GRAPHIC DISPLAY

3D DRAW	23
---------------	----

Section 5: FILE UTILITIES

Utilities Menu	24
----------------------	----

Section 6: MACHINING

Part Machining (DNC)	33
----------------------------	----

Chapter 1: INSTALLATION

Insert Disc

Probe Interface

Fadal machines are fitted for the Renishaw Probe to the interface. Use the following procedures to install the interface and hardware to the Fadal VMC.

Mounting The Interface Box

The interface box is equipped with a speaker that sends an audio signal each time the probe touches the pattern. The signal may be toggled on or off. Use the following procedure to mount the interface box for the MP-1 probe.

- 1) Place the interface box on top of the VMC pendant or some other safe location.
- 2) Feed the wire with the five prong plug to the spindle.
- 3) Feed the three prong wire to the VMC control box on the right hand side of the machine.

Note: Check the batteries in the MP-8 probe before use.

Note: Steps 2 and 3 are disregarded for the MP-8 probe.

Connecting The Interface

Use the following procedure to install the interface wire to the mother board inside the VMC control box.

- 1) Turn the VMC's power OFF.
- 2) Use an electrician's hole punch to punch a 7/8 hole in the bottom of the control box.
- 3) Install an appleton fitting.
- 4) Feed the three prong wire from the interface box through the hole into the control box.
- 5) Insert the leads into receptacle J12 on the 1060 board (motherboard) as follows;

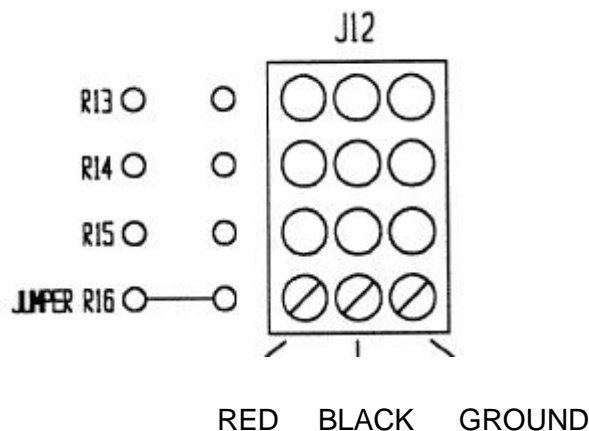

- 6) Solder a jumper at R16 on the 1060 board (see figure above)

Renishaw Probe Installation

Use the following procedure to install the probe into the spindle.

- 1) Turn the VMC's power ON.
- 2) Orient the spindle in the locked position (M19).
- 3) Install the probe into the spindle.
- 4) Insert the five prong plug (for the MP-1) into the probe receptacle.

Testing The Interface

There are two procedures for testing the probe interface. Use the following procedure to test the interface after initial installation of the interface.

- 1) At the VMC's keyboard, type DI, and then press the key to begin the diagnostic mode.
- 2) Type DS and then press the key to display switches.
- 3) Locate PROBE 01 in the display.
- 4) Toggle the stylus on the probe to activate the switch. PROBE 01 is then displayed as PROBE 00, the interface has been properly installed.
- 5) Type X and then press the key to exit the diagnostic mode.

In following the above procedure if the switch does not toggle from 01 to 00, verify that steps 1 through 3 were correctly completed.

The UT command may be used to test the probe interface before each use. Use the following procedures to accomplish this test:

- 1) Enter the UT command.
- 2) Select the TEST MP PROBE option.
 - a) The following messages appear:
PROBE TEST
1) PRESS THE START KEY WHILE DEPRESSING THE PROBE SENSOR
<
 - b) Hold the probe sensor to any limit and press the Start key. The following message appear:
2)RELEASE THE PROBE SENSOR AND PRESS THE START KEY
 - c) Release the sensor and press the Start key. The message **PROBE TEST =** will indicate whether the test passed or failed. If the test failed, check the interface connections and repeat the steps above.

Software Installation

Digitizing software is a series of programs to drive the VMC to digitize, manage data and machine a part via the RS-232. The software resides on the disks.

For efficient Probe operation a high performance computer is preferred. The software is intended to be operated installed on a hard disk system. The following procedures are a guideline for installation onto your computer's hard disk drive:

- 1) Make a PROBE directory from your root directory.
- 2) Make a DATA subdirectory from the PROBE directory.
- 3) Change directories to the PROBE directory.
- 4) Place the Probe software diskette into the appropriate disk drive (A:).
- 5) Use the DOS command COPY A:*. * and press enter.
 - a) This copies all files from the A drive to the PROBE directory.
- 6) At the PROBE prompt, type PROBE to begin the program.

Computer Interface (RS-232-C)

A special interface called a line driver is recommended for high speed communication between the computer and the VMC computer. Although a standard RS-232-C interface cable can be used between the two devices. Environment and the length of the cable limits the speed of communication.

EXAMPLE:

Standard RS-232-C Cable Length at 9600 Baud - 12 ft.

Line Driver Cable Length at 9600 Baud - 1000 ft.

Power Supply for the PC Computer

Complex electronic equipment is commonly sensitive to inconsistent power conditions. These conditions affect the voltage and the current available at a wall socket. Computers are more sensitive to electrical disturbances since the bits (binary digits) in memory, disks, and cassette tapes are stored as small electrical and magnetic charges. It may be necessary to purchase an electrical line filtering unit (surge protector) or to run a separate, isolated line to the computer.

Environmental Contaminants

The air in the room where the computer is operated should be well ventilated and filtered, free of smoke. These diskettes are TOO important to take chances with them

Static Electricity

Computer components are sensitive to static electricity which can be conducted through the operator. It is possible to erase the bits in memory and disks if a static charge hits the components in which they reside. Sometimes it takes only a tiny charge, too small to feel, to alter or destroy the information. If the operator is carrying a static charge, it will discharge into the computer when the keyboard is touched.

This problem is minimized when placing the computer in an uncarpeted room or by utilizing a grounded, conductive floor pad over existing carpet.

There are commercially available anti-static compounds, like Static Guard, which may be sprayed on carpeting, but their effectiveness is temporary.

The simplest solution is, before touching the computer or diskette, first touch a grounded object with your hand. Doing this will discharge any static electricity and you can safely touch any part of the computer system,

If there is nothing metal near the computer, secure a metal strip in front of the computer and run a wire from this strip to a grounded object. Touch this strip before touching the computer.

Disk Handling Precautions

Information is stored on a disk on magnetic particles, it is very easy to disrupt their order. Diskettes require handling with great care (see reverse side of diskette's envelope). We recommend that you follow these general guidelines in using them:

- 1) Never touch the exposed portion of the disk. Handle it by the jacket.
- 2) Keep the disk in its envelope when not in use.
- 3) Keep the disk away from all magnetic fields (i.e. speakers, power supplies, motors). These will disrupt the magnetic particles on the disk, thus destroying the information on the disk.
- 4) Store your disks in a vertical position, out of direct heat and sunlight. A disk should be stored in the environment in which it is going to be used to avoid problems due to expansion and contraction.
- 5) When a disk drive is running, the LED light will be on. Never insert or remove a disk from a running drive.
- 6) Avoid contamination of the disk. Cigarette smoke or ashes, dust, oil or spray coolant will damage a disk. Store in an enclosed box.
- 7) Make sure that the disk is not in its envelope whenever you write on the envelope. Always use a FELT tip marker when writing on the disk label.

Many factors affect the performance of disk. One of the most important is the quality of disk.

Note: It is very important that you maintain backups of your CNC data files

Chapter 2: START UP

Main Menu

This program may be run from the floppy diskettes: however, for best results it is recommended that a hard disk is used. Refer to Software Installation in Chapter 1. After the installation procedures, change directories to the PROBE directory. Type PROBE to start the probe software. The software's Main Menu is displayed as follows:

VMC Digitizing

- 1) Digitize From Beginning
- 2) Resume Digitizing 3D Program
- 3) 3D Draw
- 4) Machine Part CDMCD
- 5) Digitize Options
- 6) File Utilities
- 7) Exit To Dos

Enter Selection Number

The software displays a menu when there are multiple possibilities. Each time a menu is presented, a message will follow asking for a response. Select the number corresponding to the desired function and press the ENTER key. To initiate any digitizing process use the Digitize From Beginning option. Options 2 through 6 are ONLY useful after the digitizing process has been started or completed.

Exiting the Software

Exit to Dos

This option is selected to exit the Probe Software. When this option is selected the following message appears:

Respond With (Y) To Execute A Shell Command or (N) To Return To Dos_

Press the letter Y to execute a Shell command. This option returns to DOS WITHOUT exiting the Probe Software. You MUST type EXIT and press ENTER, at any DOS prompt, to return to the Probe Software Main Menu. If this option is selected the Probe Software remains active in the computer memory.

Press the letter N to exit the Probe Software. The program is no longer active in the computer memory.

Data Entry

To select items from any menu, type the number of the option and press the ENTER key. When entering data on any menu the function keys, at the bottom of the screen, may be pressed at any time. This allows the user to input only those items that are different than the defaults.

Warning: To ensure proper operation of all software functions it is NECESSARY that all data entries be made with CAPITAL letters.

Setting The Z Axis

Setting The Probe

Before beginning the digitizing process the Z axis home MUST be set. Set the Z axis home , for the probe, at the tool length offset point. The digitizing starting position is the absolute position from this point. This allows for the use of tool length offsets for the cutting tool. After the digitizing is completed the Z axis home MUST be reset to the original home position,

Setting The Tool

The tool length offsets MUST be set at the same point that the probe Z axis home was set. The program Z axis moves will then correlate from the probe to the tool

Chapter 3: DIGITIZING

Digitize From Beginning

This function is used to begin the digitizing operation. To select this function from the Main Menu, press the 1 key and then press the ENTER key.

There are two methods of digitizing, XY Pattern and XZ, YZ Pattern. The software prompts for a response to make a selection choose between an XY Pattern or an XZ, YZ Pattern.

Digitizing Movement

- 1) XY Pattern
 - 2) XZ, YZ Pattern
- Enter Selection Number

Select the desired digitizing operation and enter its corresponding number.

XY Pattern (2D Path)

XY Pattern is a method of digitizing two dimensional patterns having undefined edges in the XY plane. The software generates an XY path for probe motion around the perimeter of the pattern. The probe digitizes this pattern to create an XY pattern file. The probe path can be a closed looped pattern, connecting the start and end point, or it can be defined without connecting the ends. The following screen appears after the XY Pattern is selected

	2D Digitizing	
Create XY Pattern File		

Enter File Name To Create C:

2D Path File Names

Specify a file name for the digitizing data. The name is how the computer can organize and identify the data stored on a disk. The maximum name length is eight characters. Use an alpha character for the first character followed by numbers or letters. Do not use characters such as !@#\$%*&*() or "spaces". The software automatically appends an extension to the specified file name.

Example: ABCD1234.2DM

ABCD1234 identifies the filename. The .2DM identifies the filename extension. This extension is automatically added to the filename for 2D files.

Z Levels

After a file name has been entered, the software prompts for a response to "**Enter That number of z Levels**". **Z** levels identify the number of levels to be digitized. This feature is used when undefined edges of patterns are stacked like a stair case.

An input of 3 Z levels is required. Parameters such as starting position, segment length etc., are set for each one of the levels. The probe digitizes one level at a time. Upon completion of digitizing the first level the probe is positioned to the starting position of the next level and digitizing is resumed.

Enter the number of Z levels at the prompt. There can be NO MORE than 100 levels defined.

Z Definition

The software displays the following message for Z definition:

Z Definition

1- Incremental Up or Down

2- Absolute Positions

Enter Selection

Z Definition is used to define the method of specifying the Z Starting Position. This message is only displayed when two or more Z levels have been specified.

Option #1 automatically increments the Z absolute coordinate in the positive or negative direction. This is used when the distance between Z levels are equal. This option prompts the message:

Enter Starting Z Position_

After entering the starting absolute Z position the increment is prompted as follows:

Enter Z Increment_

This increment may be either positive or negative.

Option #2 requires that the absolute Z starting position will be manually entered for each level through the Parameter Settings.

After either option data has been entered the Starting Data screen is displayed.

Starting Data

This screen allows for input of up to four lines of program code. These program lines are executed prior to the probe sequence. These lines are typically used for modal preparatory data for the probing sequence. They may also be used to move to a specified position prior to beginning each digitizing level. This screen will appear before the parameter settings for each Z level.

Starting Data For Level # 1

1> _
2> _
3>
4>

Press the F1 key to continue to the parameter settings. Press the ESC key to clear any previously entered data.

Parameter Settings

A full screen of parameter settings is displayed for 2D Path definition.

Z Level #1

Starting X Position= 0.0000
Starting V Position= 0.0000
Starting Z Position= 0.0000

Z Clearance Position= 0.000

Termination of XY Digitizing
(Answer 1, 2 or 3)

- 1) Total Distance= 0.000
- 2) Termination XY Zone
X Greater Dimension= 0.000
Y Greater Dimension= 0.000
- 3) Closed Pattern (Y or N)=Y

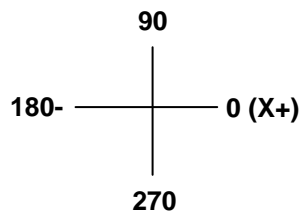

Approach Angle= 0

Note: DO NOT Approach Perpendicular

Segment Length= .025

Min.= .005 Max.= .25

Probe Movement Along Pattern

1 = Left Of Pattern -Climb

2 = Right Of Pattern -Conventional

Enter Direction #=1

Press The Esc Key To Continue

Enter the appropriate setting for each parameter. To advance to each parameter press the ENTER key. After all data is entered press the ESC key to continue. A page of, starting data then parameter settings are displayed for each Z level. Each screen is displayed upon pressing the ESC key.

Starting Position;

The X, Y, and Z starting positions are the absolute coordinate in relation to the set home (SETH) position on the VMC. It is from this position that the probe advances the pattern.

Z Clearance Position:

The Z Clearance Position is an absolute coordinate to which the probe is positioned upon termination of digitizing. It is at this position the probe can be positioned in the XY plane without obstruction.

Termination of XY Path:

This setting is used to define the terminating point of the digitizing operation. There are three different options to end 2D digitizing. Total Distance, Termination XY Zone and Closed Pattern. One of the three options must be specified.

Option #1 is used for digitizing segments of circumscribed patterns. Estimate and enter the total distance of probe travel, from the beginning of the segment to the end.

Option #2 confines probe motion to within an area. The X and Y Greater Dimension are in relation to the starting position. When the probe tries to digitize beyond the specified greater dimension, digitizing is terminated.

Option #3 is used when digitizing completely around the perimeter of a closed pattern.

Segment Length:

Segment length is a factor that is used in constructing the probe path around a pattern. The path is simultaneously constructed while digitizing. Segment length is the distance between the current digitized position and a point that is projected in-line with the current and last digitized positions. Four points, current position included, are then positioned equally spaced around the projected point on a radius equal to the segment length. The probe advances to each point consecutively until contact with the pattern is achieved. Only pattern touch points are saved to the disk file.

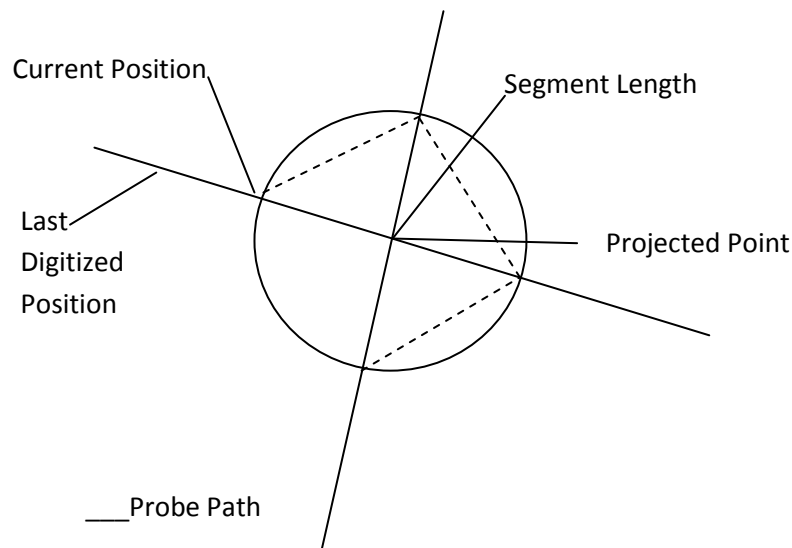

Approach Angle:

The approaching angle is the angular direction in which the probe advances the pattern from the starting position. A value of 0 to 360 determines direction. If the angular direction is Y+, the approaching angle is 90 degrees. Do not approach perpendicular to the pattern, the probe may NOT continue in the proper direction.

Probe Movement Along Pattern:

Probe motion around a pattern may either be Left of the Pattern (Climb) or Right of the Pattern (Conventional). The default is 1, Left of Pattern, pressing enter accepts this option. Select option 2 for the tool to move along the right of the pattern.

Edit Levels

When the parameters of the last level have been entered the program displays the following prompt:

Respond with (Y or N) to Edit Previously Defined Levels

A response of N directs the program to the RS-232 check. Entering a Y prompts the following message:

File [path and filename] Contains _ levels Total

Respond with (Y or N) to Change the Number of Levels

A response of N directs the program to the Starting Data screen to edit the levels, starting at level LAY response prompts the user for the new number of levels. The program is directed to the Starting Data screen for editing of the levels, starting at level 1.

The F1 key is used while editing to page forward through the levels. The F2 key is used to page backward through the levels. The F10 key is pressed, when all changes have been made, to continue. The prompts described above are displayed again.

RS-232 Check

When all parameters and/or edits have been specified, communications are then checked before starting.

XZ, YZ Pattern

The XZ, YZ Pattern is a method of digitizing XYZ coordinates on 3 dimensional patterns. After selecting XZ, YZ Pattern from the Digitizing Movement menu, the display prompts for necessary data.

Enter The Number Of Box(s) Needed To Define The Pattern _

Enter the number corresponding to the desired number of boxes. See Box Structure to determine the number of boxes to use.

Box Structures

Three dimensional box structures are used to establish boundaries around a pattern, creating an area referred to as a zone. The probe only digitizes within the user defined boxed zones. The number of boxes that are needed depends on the shape of the pattern. For example, the object below is set up to be digitized using one defined box.

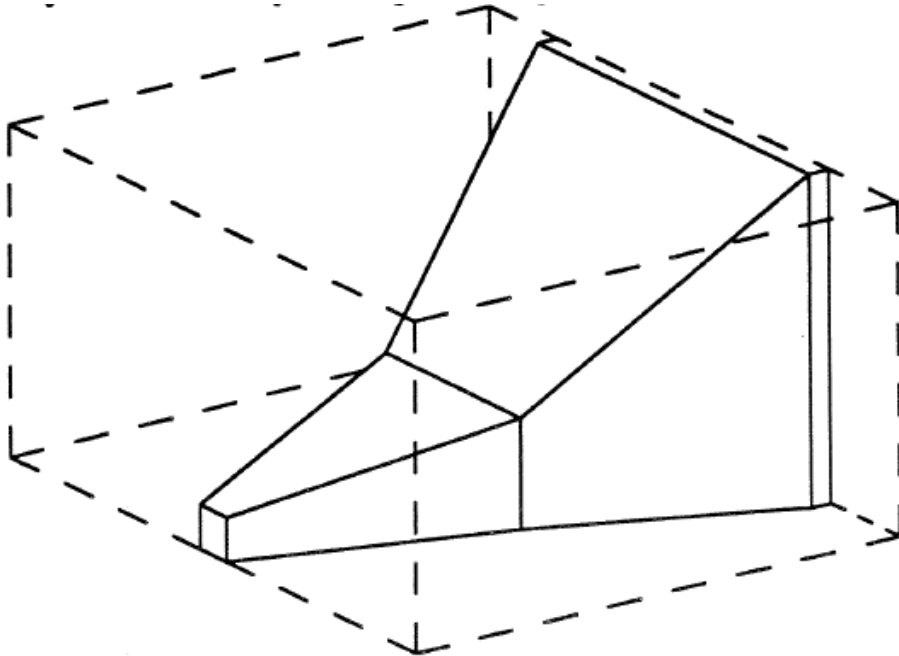

A more efficient digitizing operation is achieved by using multiple box structures. They minimize the area to be digitized thus reducing the digitizing time.

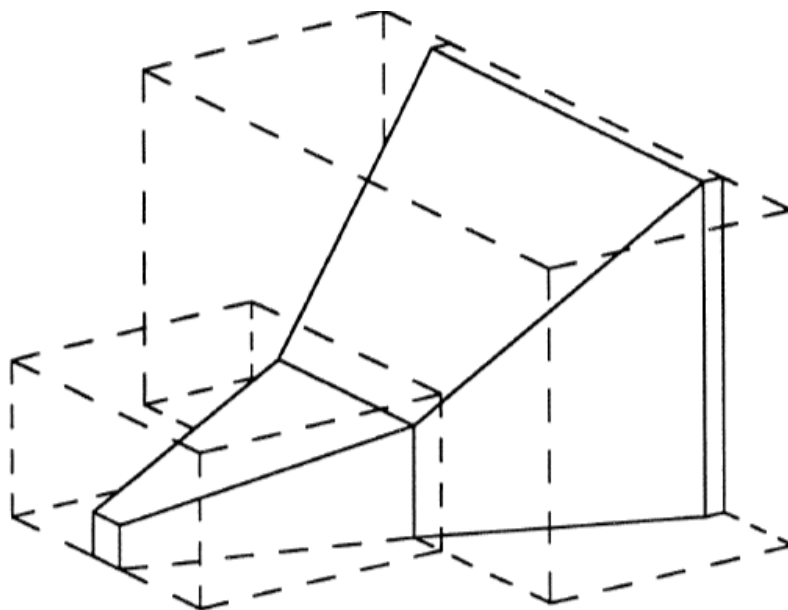

Group File Names

When entering more than one box, the software responds by prompting for a group file name. The name is how the computer can identify and organize the data stored on a disk. The maximum name length is six characters. This allows for automatic box numbering. Use an alpha character for the first character followed by numbers or letters. Do not use characters such as !@#\$% '&*() or "spaces". After entering a file name, respond with a Y or N for automatic box numbering. A Y response automatically assigns each box the group file name with a number.

EXAMPLE:

Box 1= Demo-1.prb

Box 2 = Demo-2.prb

The name DEMO is the Group file name. The -1.prb and -2.prb are automatically assigned.

A N response prompts for a filename for each box. These filenames may be up to eight characters. After entering the box filename the following prompt is displayed:

Respond With Enter to Begin Defining Each Box or M For Main Menu_

Press ENTER to begin defining each box or M to return to the Main Menu.

Single Box File Names

Upon entering only one box a prompt for a file name is displayed. Like the Group file name, use alphanumeric characters. The maximum name length for a single box is eight characters. After entering the file name the Digitizing Parameters screen is displayed.

Digitizing Parameters

Digitizing Parameters

Lower-Left Hand Corner: X= _
Lower-Left Hand Corner: Y=
Maximum Depth: Z=
Upper-Right Hand Corner: X=
Upper-Right Hand Corner: Y=
Maximum Clearance: Z=
Grid Pattern X Increment=
Y Increment=
Z Increment=
Sweeping Motion (X or Y)=
Data File Name= C:\T1-1.Prb

Enter Data Then Press A Function Key
(F1) Begin Digitizing
(F2) For Help
(F3) Clear
(F4) Main Menu
(F5) Previous Box
(F6) Next Box

The parameter settings above are used to define a 3 dimensional box and initialize the probe path.

Set the digitizing parameters as follows:

Type in the parameters. All data must be entered before digitizing can begin.

If more than one box is being defined, use the function keys to advance to the next page of parameter settings.

Help is accessible by pressing the F2 key.

Once all data is entered, press the F1 key to begin digitizing.

Defining Box Structures:

Construction of a box begins on a 2 dimensional plane by plotting the absolute XY coordinates of the lower left and upper right hand corners of a rectangle or square. The third dimension is added by specifying a Z coordinate in the MAXIMUM CLEARANCE and MAXIMUM DEPTH parameters. The probe only digitizes within the defined zone.

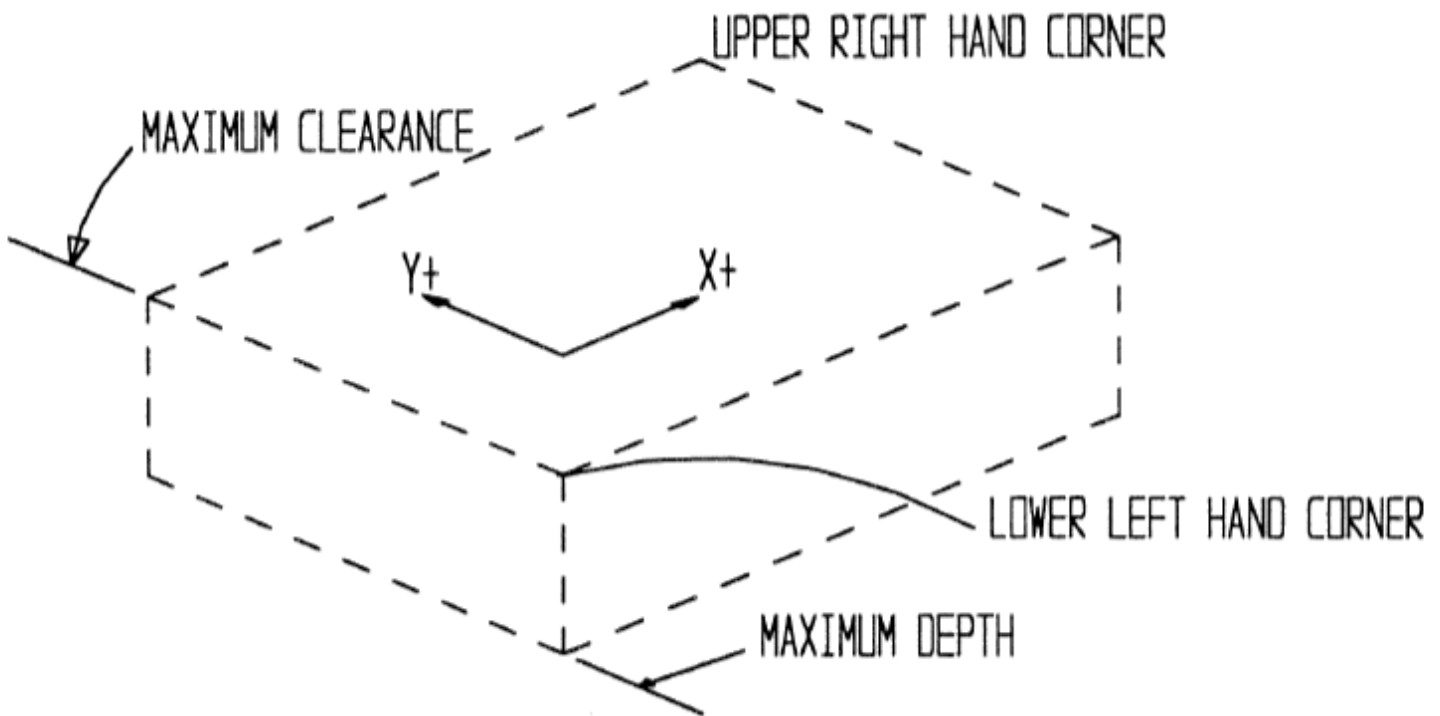

The software positions the probe to XY coordinates within the box structures. These XY coordinates are referred to as grid points. In the XY plane grid points are viewed by creating a grid pattern on the box. The distance between each point is specified by the Grid Pattern X and Y Increment Parameters.

The probe advances to each consecutive grid point by rows. Sweeping motion is in the X or Y direction. If an X sweep is entered, the row of grid points to be digitized parallels the X axis. If a Y sweep is entered, the row parallels the Y axis.

Digitizing begins at the lower left hand corner of the first box, advancing the Z axis from the Maximum clearance plane to the maximum Z depth. Stylus contact with the pattern causes the current absolute XYZ position to be registered and stored in the data file. The software will then retract the Z axis in the plus direction at the specified Z increment, and then advance the probe to the next grid point.

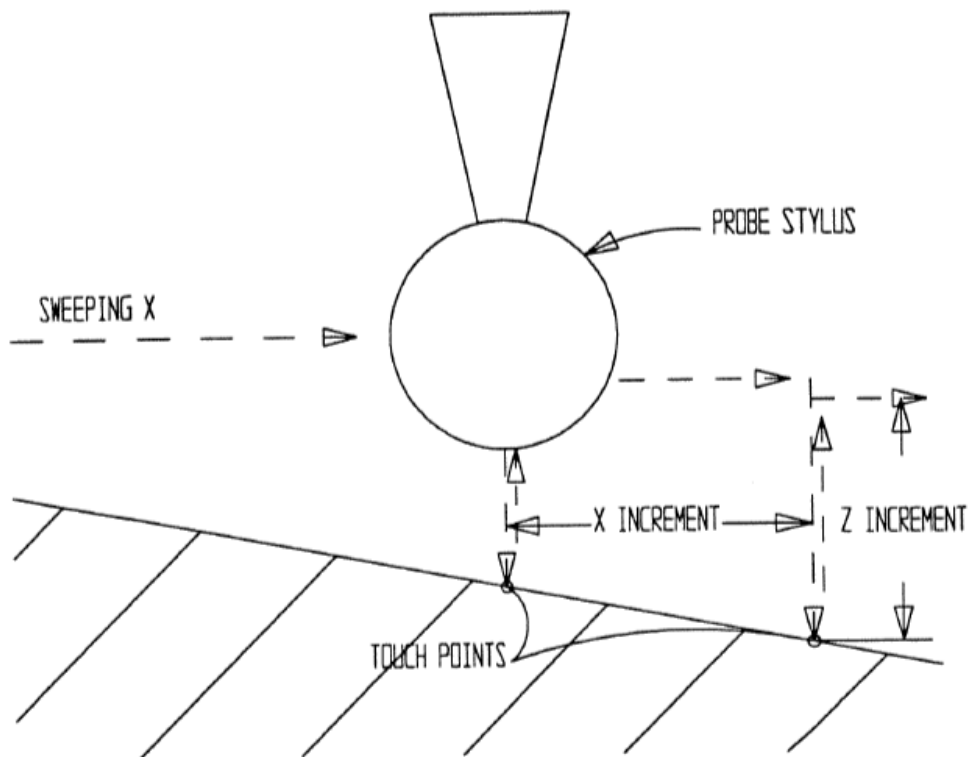

Probe contact with the pattern before reaching the next grid point delays advancement until the Z is positioned to a higher plane. This procedure is repeated until the remainder of the X or Y increment is complete.

Function Key Options:

To perform specific options press the appropriate function key. The function keys perform as follows:

F1 begins the digitizing process.

F2 displays the help screen.

F3 clears the current parameters on the screen. The parameters are ready for input.

This is not necessary to input parameters, the backspace key may be used to edit the parameters.

F4 return to the main menu without executing the digitizing.

F5 returns to the previous box parameter screen.

F6 displays the next box parameter screen.

Begin Digitizing

Press the F1 key to begin digitizing. The software will then prompt for a response to verify the probe path.

Respond With (Y or N) To Simulate The Digitizing Path

This function graphically displays the path direction of the probe. To view the initialized path, press Y and then press ENTER. A 3D box is displayed in which the path can be monitored. To ignore this function, type N and then press ENTER.

The software reads the file names on the data disk drive. If an existing data file has been entered, the display prompts for a response;

Data File Name Box-1 Already Exist

Respond With (Y or N) To Overwrite It

To enter a new data filename press N, the software then displays the Digitizing Parameter page. Press Y to overwrite the existing data filename. Digitizing data is then displayed.

<table border="1"><tr><td>Starting Position</td></tr><tr><td>X 0</td></tr><tr><td>Y 0</td></tr><tr><td>Z 1</td></tr></table>	Starting Position	X 0	Y 0	Z 1	<table border="1"><tr><td>File Information</td></tr><tr><td>File Name=C:\T1</td></tr><tr><td>Estimated Data Size = Unavailable</td></tr><tr><td>Probing Number of Points Unavailable</td></tr><tr><td>Estimated Time= Unknown</td></tr></table>	File Information	File Name=C:\T1	Estimated Data Size = Unavailable	Probing Number of Points Unavailable	Estimated Time= Unknown
Starting Position										
X 0										
Y 0										
Z 1										
File Information										
File Name=C:\T1										
Estimated Data Size = Unavailable										
Probing Number of Points Unavailable										
Estimated Time= Unknown										
<table border="1"><tr><td>Movement</td></tr><tr><td>Multiple Zones</td></tr></table>	Movement	Multiple Zones	<table border="1"><tr><td>Digitize Parameters</td></tr><tr><td>Retrace Tolerance=Off</td></tr><tr><td>Angular Deviation= Off</td></tr><tr><td>Secondary Increment=Off</td></tr><tr><td>Primary Approach Feed= 30.</td></tr><tr><td>Secondary Approach Is On</td></tr><tr><td>Secondary Feed= 1.</td></tr></table>	Digitize Parameters	Retrace Tolerance=Off	Angular Deviation= Off	Secondary Increment=Off	Primary Approach Feed= 30.	Secondary Approach Is On	Secondary Feed= 1.
Movement										
Multiple Zones										
Digitize Parameters										
Retrace Tolerance=Off										
Angular Deviation= Off										
Secondary Increment=Off										
Primary Approach Feed= 30.										
Secondary Approach Is On										
Secondary Feed= 1.										

Press any key To Begin or F10 To Return To The Main Menu

Press any key to begin digitizing, To abort, press the F10 key.

Note: For long term digitizing, be sure to fill the VMC waylube reservoir.

Resume Digitizing 3D Program

This function is used to resume 3D digitizing. The initial digitizing operation may be aborted at any time during the operation. Only 3D programs can be resumed.

Enter 2 from the Main Menu to resume. The software will then display a series of prompts to enter a group or single box file name.

The software then displays the file name to be resumed, the last row and block digitized and the parameter settings for the last box structure. Enter a Y to resume the digitizing operation or N to abort.

Digitize Options

Selecting option 5 of the Main Menu will display the options for digitizing. Options 4 through 10 apply to 3D Grid Pattern.

Change Settings

- 1) Default Data Drive\path= C:\
- 2) Communication Port# 2 At 4800 Baudrate
- 3) Video Adapter= UGA [Color Off]
- 4) Primary Approach Feedrate= 30.
- 5) Secondary Approach (On\off)= On
- 6) Secondary Approach Feedrate= 1.
- 7) Angle Tolerance= 90 Degrees
- 8) Retrace (On/off)= Off
- 9) Retrace Tolerance= 0
- 10) Secondary Increment= .001
- 11] Save And Return To Main Menu

Enter Selection Number _

Select the corresponding number of the option to be set and then press ENTER.

Default Data Drive\path=

This setting is used to change the data drive. Data is stored to drive A: B: C: or C:\Path\. The "\" at the end of the path MUST be entered for correct operation. Select the desired drive and press ENTER.

Communication Port #2 at 4800 Baudrate

This setting is used to select the communications port through which data is transmitted and received. The speed at which data is transmitted via the RS-232 is also selectable. For more information on RS-232, see COMPUTER INTERFACE (RS-232-C)

Video Adapter=

Select this option to select the proper video adapter in your computer. After selecting the video adapter, the software prompts for a response to enter a Y or N for color. When color is desired, press Y and then press ENTER. A color chart is then displayed on the monitor. Colors can be selected for characters, display background and borders. Press N if color is not desired.

Primary Approach Feedrate=

This setting is used to set the feedrate for the primary approach, which is the probe XYZ advancement to each grid point. Feedrates and accuracy are interrelated, slower axis feedrates enhance pattern duplication.

Secondary Approach (On/off)=

In addition to die primary approach, the secondary approach will assist in maximum accuracy. Turn this function on when a secondary approach is desired.

The probe makes the primary approach at the specified feedrate and touches the pattern. The Z axis is then retracted in the plus direction .015, and then retouches the pattern advancing the Z axis at the specified feedrate indicated in the Secondary Approach Feedrate setting.

Secondary Approach Feedrate=

Enter a feedrate when the secondary approach is selected.

Angle Tolerance=

When an angle between two digitized grid points is greater than the specified Angle Tolerance, the retrace method of digitizing is activated automatically (see Retrace (On/off) =). Enter 90 if automatic retrace is to be ignored.

Retrace (On\off)=

This setting turns the retrace operation on or off. Retrace is a method of digitizing in which the probe after digitizing a grid point, is positioned above the pattern to a specified surface tolerance and then retraces the angular lath to the last grid point. Stylus contact with the pattern on retrace causes the probe to be positional to the previous digitized grid point. The digitizing is then resumed between the two grid points using the secondary increment. This method of digitizing is used when the most detail is desired.

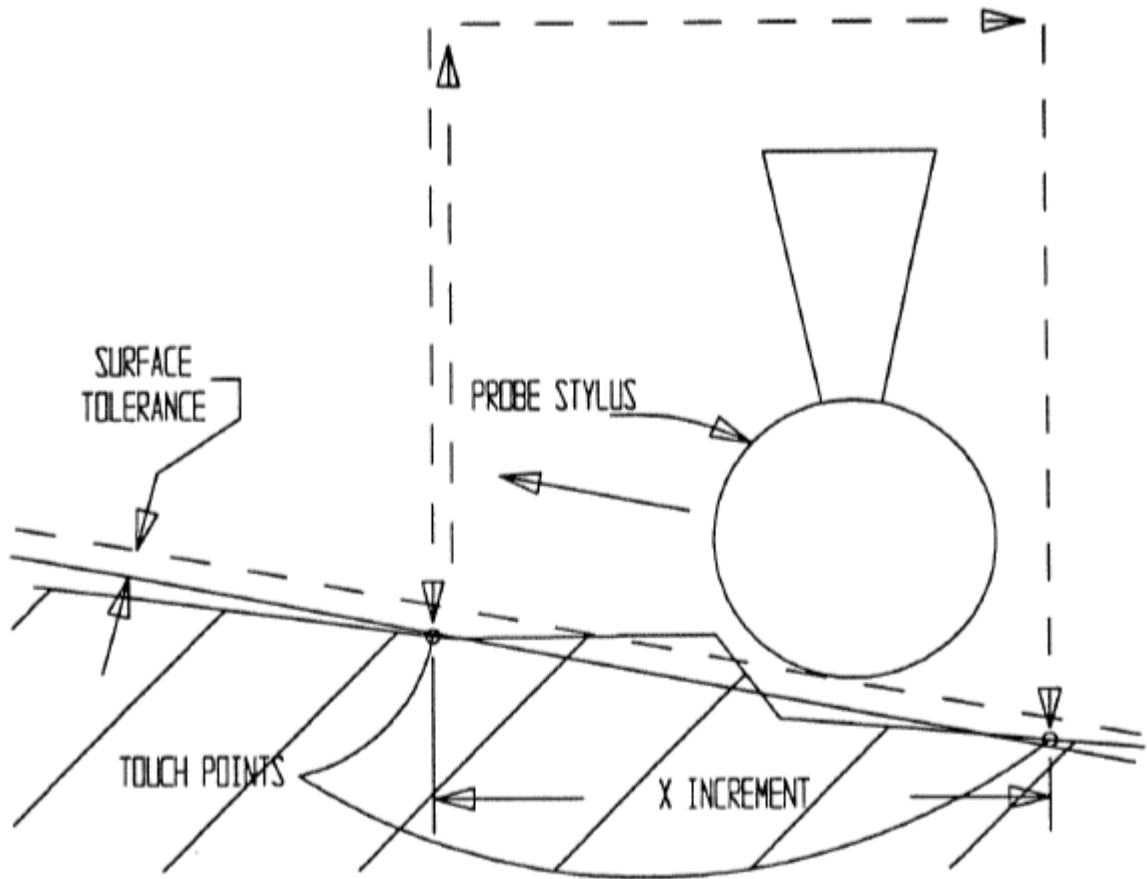

Retrace Tolerance=

The Retrace Tolerance must be specified when Retrace is selected. It is the distance between the pattern relative to probe movement on the retrace. For example, specifying a .025 surface tolerance the probe will retrace from one grid point to the previous digitized point .025 above the pattern.

Secondary Increment=

Secondary Increment is an increment that is invoked when retrace is selected, or an angular transition is greater than the specified Angle Tolerance (see Angle Tolerance=). Enter an increment up to one fourth of the primary XY increment. For example, if the primary XY digitizing increment (Probing Parameters) is .100, a secondary increment of .025 or larger is specified for retrace to be effective.

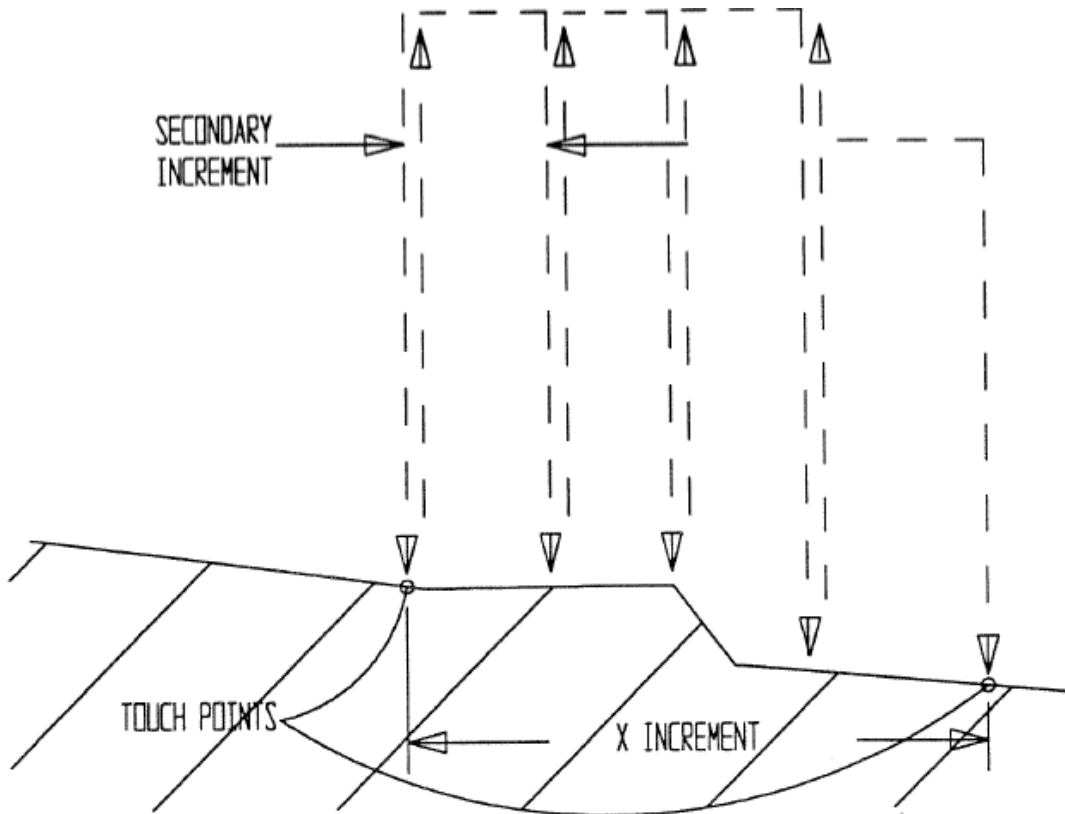

Save And Return To Main Menu

This function saves the settings and returns the display to the Main Menu.

Chapter 4: GRAPHIC DISPLAY

3D DRAW

3D Draw is used to graphically display data files on the PC monitor. To select this function, enter option #3 from the Main Menu. The software then prompts for a response;

Respond With (Y or N) To Draw A Group File Name

All box structures stored under the Group File Name are drawn if a Y response is entered. Enter an N if a group file name is not desired, and then enter the file name to be drawn.

Notice at the bottom of the display a prompt to Press Enter to Begin or H for Help. Help identifies key functions during 3 different draw displays. View the Help display before drawing to familiarize yourself with these key functions.

To begin drawing press the ENTER key. A box structure(s) is then displayed. The following is a list key functions to set the display before drawing

Functions While Rotating A Box

- A - zeros the rotation angle, displays box(s) 2D
- B - toggles the box(s) structure invisible
- I - initialize or reset display
- N - selects a new file
- U,D,L,R - pans display up, down, left or right
- ENTER - begins drawing
- Arrow keys - rotates box(s) to desired angle
- +, - - zooms box(s) display

Functions While Drawing

- F1 - pause drawing
- +, - - controls speed of drawing
- other keys - terminates drawing

Functions During Pause

- C - start/stop copying data to a file
- D - toggles XYZ position display on/off
- R - reset scale factor
- Z - scales display relative to the current point

Chapter 5: FILE UTILITIES

Utilities Menu

File Utilities is a series of utility programs to manage and edit data files. To select File Utilities from the Main Menu press the number 6 key and then press ENTER. A two part Utility Menu is then displayed.

Function key F1 is used to display a directory of files stored in the current data path. Function key F2 toggles the Utilities menu display. Press the F10 key to return to the Main Menu.

From the Utilities menu enter the number corresponding to the function to be performed. The software then prompts for a response to enter necessary data or to make a selection from other menus.

Utilities	
1)	Scale
2)	Layer
3)	Rotate
4)	Convert To DNC File
5)	3D Draw
6)	Copy
7)	Delete
8)	Edit
9)	List
10)	Move

Enter Selection Number _

1) Scale

This utility program is used to enlarge or reduce the size of the original pattern. A separate file is created to contain the scaled data. The original digitized data file is not effected by this utility.

The scale ratio is determine by the XYZ scale factors. For example, a .8 scale factor reduces the size of the pattern by 20 percent.

Scaling origin is a fixed XYZ coordinate in which scaling centers.

This utility may be used to mirror a pattern. To mirror a pattern use a -1 factor for the axis to mirror. The other axes use a +1 factor. To maintain either a climb or conventional cut use option #19, Reverse 2D Path, prior to the Scale utility.

2) Layer

This utility creates a roughing program by layering the point file. Roughing passes are added to enhance machinability. A roughing program is generated by layering a point file. This causes the cutting tool to rough excess material in different layers.

3) Rotate

This utility rotates point files around a coordinate. The program reads the file that contains the digitized XY points. Then it rotates the coordinates and stores the data. The source file is not affected by this utility. The following questions are displayed as each answer is entered.

Enter Source File Name

Enter Destination File Name

Enter Total Number Of Patterns ?

Only One Pass will Be Generated

Enter Starting Angle

Enter The X Coordinate Of Rotation Center From Abs. Zero ?

Enter The Y Coordinate Of Rotation ?

Respond With (Y or N) To Begin

Incremental and absolute coordinates are allowed to be rotated. With absolute coordinates both X and Y characters must be stated on each data block.

4) Convert To DNC File

This utility program converts digitized data into an high speed DNC data file. The digitizing operation records absolute XYZ coordinates. Converting these absolute points to incremental XYZ moves eliminates CNC processing time.

	File Utility	
Create High Speed DNC File		

Respond With (Y or N) To Convert A Group File

Enter Source File Name

Enter Destination File Name

5) 3D Draw

This utility is the same as option #3 of the Main Menu (See Graphic Display).

6) Copy

This utility copies an existing file to another file name. Duplicating a file is useful when editing is desired and the original is to be maintained.

7) Delete

This utility deletes an existing file from the data disk.

8) Edit

The editing program will enable editing functions on data files. Data files not exceeding 60KBytes in size, are loaded into the memory of the computer for editing. The program uses a menu system listing editing commands. Each editing command is referenced by two alpha characters. For example, LI for list, CH for change, PR for print etc.. Enter the 2 characters corresponding to the editing function to be performed.

Note; Files larger than 60KBytes cannot be edited with this editor. Use a word processor for files of this length.

```
PROBE TEXT EDITOR  
  
IN TO INPUT PROGRAM  
  
LD LOAD DISK FILE  
  
MU TO SEE MAIM MEMU  
  
<ENTER YOUR COMMAMD>
```

9) List

This utility displays data files on the PC computer monitor. Editing functions are not permitted (See Edit).

10) Move

This utility moves a data file from the active data drive to another drive in the computer.

Press the F2 key to display the continued menu.

Utilities

- 11) Print Out
- 12) Ite-232 Test
- 13) Ruled Surface
- 14) ZD Circle Blend
- 15) Part-Line
- 16) Combine Group Files
- 17) Backup To/From Diskette
- 18) Mark End Of Column
- 19) Reverse 2D Path
- 20) Segment File

Enter Selection Number

11) Print Out

This utility sends the data file text to an attached printer.

12) RS232 Test

This utility tests the communication ports on the computer. The software prompts the operator to install the Rs-232 Test Plug. Install the Test Plug into the selected communication port (see Digitizing Options, Comm. Port selection) or jumper pins 2 and 3. The test is initialized by sending a character out through the transmit pin (pin # 2), which is then received by the receive pin (pin # 3). The test will run continuously, transmitting alphanumeric characters.

File Utility p

RS-232 Test Ver. 2

There Two Procedures For A Test:

- 1) Install The RS-232 Test Plug (or Jumper Pins 2 And 3) Directly In The PC Computer's RS232 Port
- 2) Connect The Computer To The CMC And Cycle The Test

Select Test Mode (1 or 2)

13) Ruled Surface

This utility file prepares a ruled surface program for machining from an existing 3D digitized file. A ruled surface is created to reduce digitizing time and enhance surface finishes during the machining operation, thus reducing the time invested in hand finishing the final product.

The software creates an additional cutter path between the sweeping digitized path. A parallel or perpendicular cutter path may be selected.

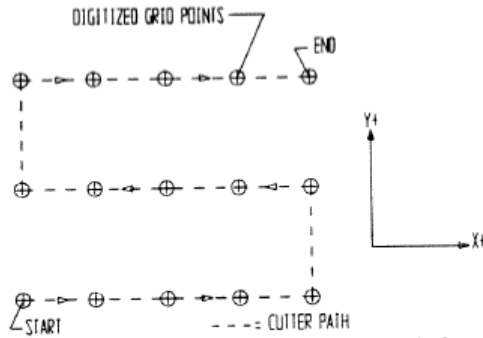

The figure above displays cutter path without using a ruled surface program. The cutter is positioned to each grid point in the sweep direction.

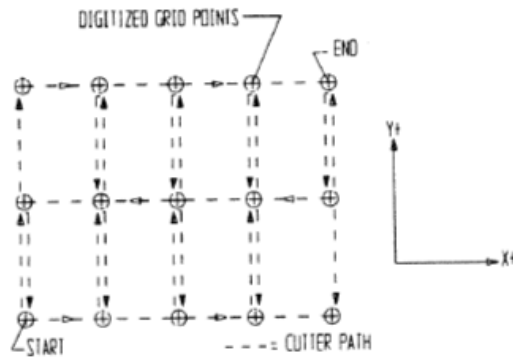

The figure above displays the same cutter path using a perpendicular ruled surface program.

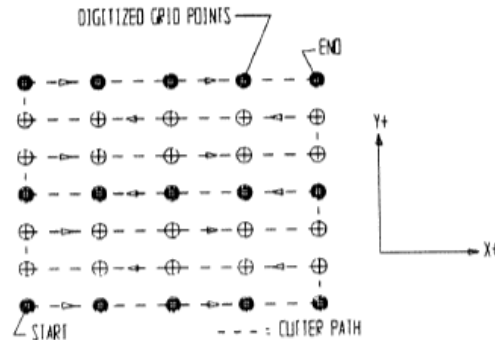

A Parallel Ruled Surface, shown above, creates a parallel cutter path between the digitized path.

14) 2D Circle Blend

2D Circle Blend is a curve fitting technique that computes circular arcs between successive pairs of points. This is useful in eliminating flat surfaces on circular shaped patterns.

The beginning and ending points of 2D pattern files are indicated by a comment in parenthesis next to the coordinates, (START and (END. Only digitized data between these coordinates are blended with an arc. Enter the filename at the prompt below to begin the circle blend function.

File Utility

Xy Curve Fit For 2D Probing

Point Source File Name C:\

15) Part-line

Part-line is a utility program that trims away XYZ coordinates from digitized data files. This is done by specifying an absolute Z coordinate that identifies the part line. The software trims above or below the part line and stores the remaining data to the specified destination file. The source file is not affected by this utility. This utility converts prb extension files to dat extension files.

File Utility

Create A Partline File

Respond With (Y or N) To Process A Group File

16) Combine Group Files

This utility combines all files of a group file into a single dat extension file.

	File Utility	
Create Single File From Group		

Enter Group File Name

17) Backup To/From Diskette

This utility is used to make backup copies of files. Select the option desired.



- 1) Save File To Disks
 - 2) Restore File From Disks
- Select Option Number

18) Mark End Of Column

This utility removes the (START and (END marks on a digitized file.

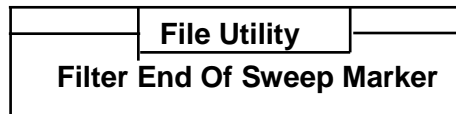

Enter Probe File Name C:\

19) Reverse 2D Path

This utility is used to reverse the direction of cut. The original 2D path file is not changed. This can be used to change from a conventional cut to a climb cut when the file is mirror imaged.

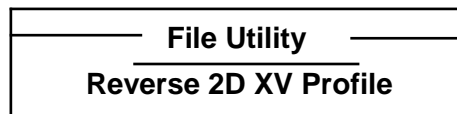

Enter 2D-Probe File Name C:\

20) Segment File

This utility is used to break the absolute program code into segments. The file is converted into incremental code. Segment lengths are calculated based upon the desired feedrate and process speed. This utility should be used when high speed machining is desired.

Fadal 3-D File Conversion U3.4

Scope:

**Read Absolute File Generated By a CAM And Create An Incremental, Equal Segment High Speed File Using G91.1
Large Moves Are Broken-Up, Small Moves Remain The Same
Circular Moves Are Not Segmented As Linear**

Enter The CNC's Blocks Per Second Capability (72 or 250) 72

The blocks per second capability is dependent upon the machining processor. The -2 processor is 72 BPS and the -3 processor is 250 BPS. Select the appropriate number for the machines processor. After selecting the process speed the desired feedrate must be entered. The required segment maximum is displayed. This segment maximum may be accepted or changed with the appropriate response. The following prompt is displayed at the bottom of the screen:

**Enter The CNC's Blocks Per Second Capability (72 or 250) 72
Enter The Desired Feedrate [.01-375] 50
Required Segment Maximum= 0.0116 Is This Acceptable (Y or N)**

**Define When To Begin Processing The File
Processing Begins After The Line That Contains A Match
For Example: H
Processing Begins After A Block With The H-WORD
Enter Nothing To Start From The Beginning**

Enter Starting Data H

The segment processing starts from the data entered here. The file is searched until the data entered is found. The file is processed from that line until the Ending Data is found. If no data is entered the program is processed from line 1. This will segment the Z length offset moves as well. It is recommended that the starting data be the H word.

Filter Options:

**Drop Lines Not Containing An X, Y, Z, M, S, G, H Word In The Block
Before The Processing Begins And After The Processing Ends
And Ignore Search Finds After The C Character
Respond With Y or N [Y] Y_**

The filter options may be used to delete any lines NOT containing an X, Y, Z, M, S, G, or H word before the processing begins or after the processing ends. They may also be used to ignore search characters in program comments..

After the filter options have been selected the prompt for the Ending Data is displayed as follows:

```
Starting Data: H\  
Ending Data : M5  
Enter Source File Name SAMPLE.ABS
```

The Ending Data is the program code that the processing is to stop at. This is normally the M5 code. The software will segment all program code between the Starting Data and the Ending Data. Using the H word, for the starting data, and the M5, for the ending data, segments the program between offset calls and the end of the tool path.

Enter the filename to process and press ENTER. The following display shows the processing being accomplish .

Completed Conversion

```
Source File:    SAMPLE.ABS  
Destination File: SAMPLE.DNC  
Time To Process: 00:00:01  
Lines Read: 31  
Lines Modified: 0  
Lines Generated: 0  
Press Any Key To Restart Or Alt-X To Quit
```

Press Alt-X To Quit

During any process screen the segment process may be stopped. Hold the ALT key down and press the X key to exit this utility to the Main Menu.

Chapter 6: MACHINING

Part Machining (DNC)

Direct Numerical Control (DNC) is a mode to control the machine through the RS-232 port, but still permits machine control functions such as AUTO start, SINGLE STEP and SLIDE HOLD etc.. Use the following procedure to begin machine operation:

- A) Select desired tool and install in spindle.
- B) Set the machining centers XYZ home position.
- C) Type CD,7 at the VMC control.
- D) Select option 4 from the Main Menu.

RS232 DNC SOFTWARE

COMMUNICATIONS PARAMETERS: BAUDRATE= 4800 USING COM. PORT # 2
PRESS ENTER TO BEGIN RS-232 TEST

Selecting option 4 from the Main Menu begins machine operation first by the software testing RS-232 connections. If the test fails, the software displays the message:

No Response: Check Cable, Enter CD,7 At The VMC

Passed Test is displayed once connections are established.

The software then prompts for a response to select a file name, starting block, and starting data for DNC machining.

Respond With (Y or N) To Begin Machining File *[filename]*

Approve the selected data file by entering Y. If another data file is to be chosen, enter N, and select another file name.

Respond With (Y or N) To Select Starting Block

Machining operation can begin anywhere in a file by selecting a starting block. Respond with a Y to select a starting block, or N to start at the beginning of the file.

Enter Starting Data [G90,G8,F40.,S3000]

The software automatically enters the shown starting data. If other data is desired such as SPINDLE ON etc., enter it in addition to what is displayed.

Press Enter to begin or F10 to Abort

Pressing the Enter key begins the machine operation by sending the DNC command to the CNC, followed by 10 blocks of data. The CNC will enter the Waiting state. Operation keys such as SINGLE STEP, SLIDE HOLD, START etc., will be functional. If the spindle is not turned on in the starting data, manually turn it on by using the SPINDLE ON/OFF and SHIFT keys. Press the AUTO key to begin the machine operation.

- E) Turn spindle and coolant on.
- F) Press the AUTO key to start the program execution.